

SPECIFICHE TECNICHE / TECHNICAL SPECIFICATIONS

C 500TK + rospe 1/2



DOTAZIONI DI SERIE:

- 2 Cassette portacomandi con con chiusura a serrandina.
- 4 Piastre appoggio stabilizzatori in acciaio
- Verniciatura a richiesta
- Scaletta mobile per accesso in cabina di manovra
- Parafanghi posteriori e anteriori
- Copertura antisdrucchiole sulle scatole portatravi degli stabilizzatori
- Riscaldamento interno cabina
- Cassetta portautensili
- 4 luci di ingombro sulle travi sfilanti degli stabilizzatori
- 2 fari girevoli arancioni sulla cabina di guida
- 2 fari di lavoro posteriori
- Conformità CE

SERIAL OUTFITS:

- 2 control boxes with rolling shutter
- 4 Outrigger support plates in steel
- Varnishing on request
- Movable ladder for access to cabin
- Rear mudguards in anti-skid aluminium
- Anti-skid covering in aluminium on outriggers beam boxes
- Heating in cabin
- Tool box
- 4 Obstruction lights on outriggers sliding beam
- 2 Orange revolving lights on driving cabin
- 2 Rear working lights
- CE certifications



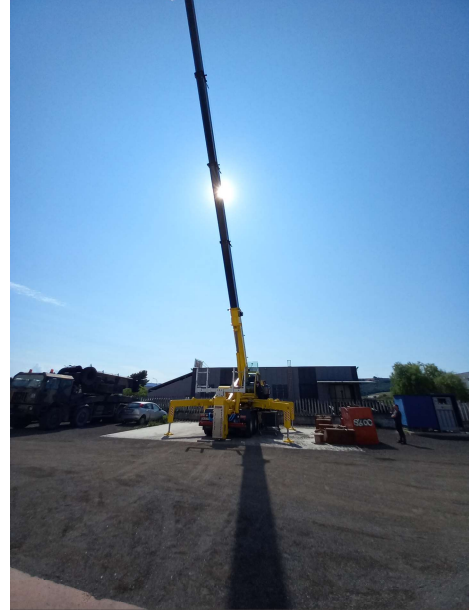

C500TK+ROSPO 1/2



C500TK+ROSPO 1/2

SPECIFICHE TECNICHE / TECHNICAL SPECIFICATIONS

caratteristiche generali / general vehicle characteristics

TIPO / TYPE

TCM C 500 BRACCIO L = 6200
gru motorizzata a libera circolazione
(a desciz. dei paesi di circolazione)

TCM C 500 BOOM L = 6200
Free circulation motorized crane
(depending on the destination country)

PORTATA / CAPACITY

50 TON a 2,5 m

VELOCITA' MASSIMA/ MAXIMUM SPEED

80/90 Km /h (in base al veicolo o alle masse) /
(according to vehicle or masses)

DIMENSIONI/DIMENSIONS

Lunghezza totale (può variare in base al mezzo) /
Total length (may change depending on the truck)

9,83 m

Altezza totale (può variare in base al mezzo) /
Total height (may change depending on the truck)

3,60 m

Larghezza trasversale stabilizzatori completamente aperti (interasse) /
Transverse width with outriggers completely open (wheelbase)

6,02 m

Larghezza longitudinale stabilizzatori completamente aperti (interasse) /
Longitudinal width with outriggers completely open (wheelbase)

5,82 m

Larghezza totale in ordine di marcia /
Total width in transport position

2,50 m

SPECIFICHE TECNICHE / TECHNICAL SPECIFICATIONS

TELAIO:

Disegno TCM Srl, progettato e costruito con lamiera di acciaio ad alto limite di snervamento per resistere alle sollecitazioni di flessione-torsione, trasmesse dai pesi statici e dinamici sollevati. Struttura autoportante monoblocco, saldata tipo cassone e scatolata internamente a nido d'ape, quattro fulcri due anteriori e due posteriori per l'alloggiamento delle scatolette portatravi stabilizzatori ad apertura radiale, fissato con staffe e viti al telaio originale dell'autoveicolo.

STABILIZZATORI:

Quattro travi costruite in acciaio ad alto limite di snervamento ad estensione orizzontale e cilindri idraulici verticali ad estensione indipendente, consentono un'ampia base di appoggio. Comandi stabilizzatori dalla cabina tramite un sistema elettro-idraulico con sicurezze uomo presente e ai lati del telaio .

TORRETTA GIREVOLE A 360°

Disegno TCM, costruito in lamiera d' acciaio ad alto limite di snervamento struttura scatolata, installata su ralla a doppio giro di sfere con dentatura interna. E' azionata con motore oleodinamico flangiato ad un riduttore epicicloidale con freno a dischi multipli sinterizzati in bagno d'olio e frenatura idraulica automatica.

BRACCIO TELESCOPICO:

A cinque elementi braccio base fulcrato sulla torretta a sezione ottagonale, costruito in lamiera di acciaio ad alto limite di snervamento, semigusci presso formati a freddo e saldati su l'asse neutro. Profilo autocentrante e scorrimento e scorrimento su pattini in materiale speciale. Estensione e rientro sotto carico, con cilindri oleodinamici a doppio effetto. 1° prolunga a sfilo indipendente. 2° e 3° prolunga a sfilo sequenziale.

ARGANO PRINCIPALE:

con riduttore epicicloidale a freno a dischi in bagno d'olio.

CHASSIS

TCM design studied to withstand deflection-torsional forces transmitted by raised weights of static and dynamic type. Self-carrying monoblock structure welded as a box honeycomb girded inside, four fulcrums, two in the front and two in the rear end housing outriggers beams with radial opening fixed with clamps and screws to the original chassis of the truck.

OUTRIGGERS

Four beams in highly resistant steel with horizontal extension and vertical hydraulic cylinders with independent extension providing a wide supporting area. Outriggers controls from cabin and from chassis sides by an electric-hydraulic system with 'man at work'-safety device.

ROTATING TURRET AT 360°

TCM design built in steel plate at high yielding level, boxed structure, installed on a bearing disc with a double turn of spheres and inward teeth. Set in action by an hydraulic engine flanged to an epicycloidal reducer with multiple disc brake sintered in oil bath and automatic hydraulic braking.

TELESCOPIC BOOM

In five elements; base boom with octagonal section hinged on the turret; built in highly resistant steel and cold-pressed semi-shells welded on a neutral axis. Self-centring profile and sliding on runners in special material. Extension and return with a load applied by double-effect hydraulic cylinders. 1st and 2nd slide extend independently, 3rd and 4th slide extend in hydraulic, sequential way.

MAIN WINCH

With epicycloidal reducer and disc brake sintered in oil bath.

DESCRIPTION DESCRIZIONE

BRANDEGGIO DEL BRACCIO:

Un cilindro a doppio effetto con velocità di discesa controllata e valvola di regolazione e blocco. Angolo di lavoro braccio da -2° a +80°.

CABINA DI MANOVRA:

Ad ampia visibilità con cristalli antisfondamento, vetro posteriore apribile per garantire una buona ventilazione, portiera ad apertura scorrevole con chiave, parabrezza e vetri laterali fissi temprati anti-riflesso. Sedile con sospensioni completamente regolabili, manipolatori idraulici nel posto di guida sui braccioli, i quali sono sollevabili. Cruscotto con strumentazione di controllo e comando, riscaldamento.

DISPOSITIVI DI SICUREZZA:

Interruttori di fine corsa in salita e discesa del carico, installati sulla testata del braccio e sull'argano con tre giri morti della fune sul tamburo. Valvola di sicurezza su tutti i cilindri idraulici, valvole regolabili di massima pressione sui distributori idraulici. Limitatore di momento elettronico.

CIRCUITO IDRAULICO:

Distributori monoblocco con valvole di sicurezza incorporate, pilotati idraulicamente tramite due manipolatori. Un filtro olio installato sui circuiti di scarico. Serbatoio olio. Raffreddamento olio tramite un radiatore elettroventilato. Prese controllo pressioni dei due circuiti idraulici. Due manipolatori idraulici con comando a croce e ritorno automatico al punto neutro, permettono di eseguire manovre incrociate e pulsante elettrico di sicurezza uomo presente.

BOZZELLO:

Portata max 50ton a 4 carrucole.

BOOM LIFTING

By a double-effect cylinder with lowering speed control, adjustment and clamping valve. Boom working angle from -2° to +80°.

MANOEUVRE CABIN

With wide visibility and safety glasses, opening rear window for good ventilation, sliding door with opening key, non-reflective front glass and side glasses. Seat with totally adjustable suspensions, hydraulic joy sticks on raisable armrests. Dashboard with control and command systems and heating control.

SAFETY DEVICES

Limit switches for load lifting and lowering installed on boom head and on winch with three fixed rope layers on the drum. Safety valves on all hydraulic cylinders, adjustable maximum pressure valve on the hydraulic distributors. Electronic load limiter.

HYDRAULIC CIRCUIT

Hydraulic distributors with incorporated safety valves, hydraulically driven by the means of two joysticks.

Oil filter installed on drain circuit. Oil tank. Oil cooling by one electro-ventilated radiator.

Intakes for pressure control of the two circuits. Two hydraulic joysticks with cross command and automatic return to neutral point providing crossed manoeuvres and electric 'man at work' safety switch.

BLOCK

Max capacity 50 ton with 4 pulleys.

DIAGRAMMI E TABELLE DI CARICO

AUTOGRU' C 500 TK Braccio 6,2m

CONTRAPPESO= 3 t

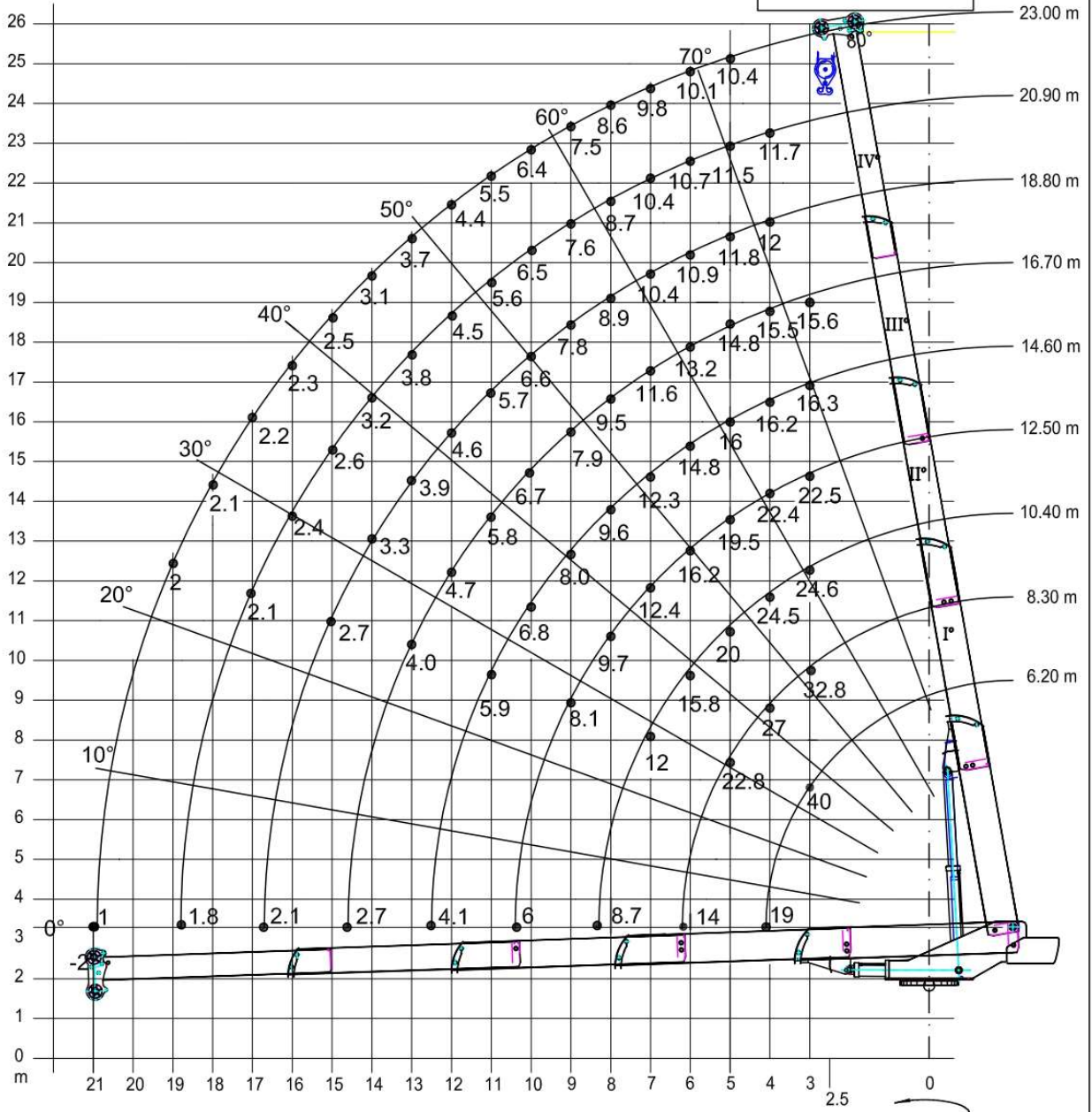

Termoli (CB) - Italy - Tel./Fax. +390875/752076 (Commerciale)

02/08/2012 Dis. Cod. C50000004

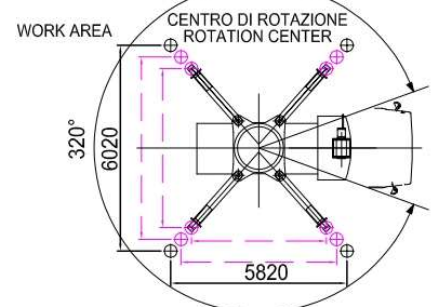

AUTOGRU' C 500
STABILIZZAZIONE COMPLETAMENTE ESTESA 6,02 m X 5,82 m – PORTATE AL 75% ESPRESSE IN t

L	6,20 m		8,30 m		10,40 m		12,50 m		14,60 m		16,70 m		18,80 m		20,90 m		23,00 m		
1	0		50		100		100		100		100		100		100		100		100
2	0		0		0		50		100		100		100		100		100		100
3	0		0		0		0		0		50		100		100		100		100
4	0		0		0		0		0		0		0		50		100		100
R, m	α°	t	α°	t	α°	t	α°	t	α°	t	α°	t	α°	t	α°	t	α°	t	
2.50																			
3.00	43.17	40.0	58.13	32.8	65.13	24.6	69.85	22.5	72.90	16.3	75.14	15.6							
4.00	20.64	24.0	48.83	27.0	58.87	24.5	64.73	22.4	68.66	16.2	71.50	15.5	73.66	12.0	75.36	11.7			
4.10	0.00	19.0																	
5.00			37.49	22.8	51.77	20.0	59.35	19.5	64.27	16.0	67.77	14.8	70.41	11.8	72.47	11.5	74.14	10.4	
6.00			19.67	16.4	43.72	15.8	53.59	16.2	59.68	14.8	63.92	13.2	67.08	10.9	69.53	10.7	71.50	10.1	
6.20			0.00	14.0															
7.00					33.94	12.0	47.29	12.4	54.83	12.3	59.93	11.6	63.66	10.4	66.53	10.4	68.81	9.8	
8.00					19.19	9.4	40.14	9.7	49.63	9.6	55.74	9.5	60.11	8.9	63.44	8.7	66.07	8.6	
8.30					0.00	8.7													
9.00							31.50	8.1	43.94	8.0	51.30	7.9	56.43	7.8	60.26	7.6	63.27	7.5	
10.00							18.90	6.2	37.48	6.8	46.54	6.7	52.56	6.6	56.97	6.5	60.39	6.4	
10.40							0.00	6.0											
11.00									29.71	5.9	41.32	5.8	48.46	5.7	53.54	5.6	57.41	5.5	
12.00									18.70	4.7	35.41	4.7	44.05	4.6	49.93	4.5	54.32	4.4	
12.50									0.00	4.1									
13.00											28.34	5.9	41.32	5.8	48.46	5.7	53.54	5.6	57.41
14.00											18.57	3.2	33.76	3.3	41.99	3.2	47.71	3.1	
14.70											0.00	2.7							
15.00													27.25	2.7	37.48	2.6	44.12	2.5	
16.00													18.46	2.3	32.40	2.4	40.25	2.3	
16.70													0.00	2.1					
17.00															26.37	2.1	36.02	2.2	
18.00															18.38	2.0	31.26	2.1	
18.90															0.00	1.8			
19.00																	25.65	2.0	
20.00																	18.32	1.8	
20.90																	0.00	1.0	
21.0																			
22.0	COD. C5000004																		



DIAGRAMMI E TABELLE DI CARICO

AUTOGRU' C 500 TK Braccio 6,2m

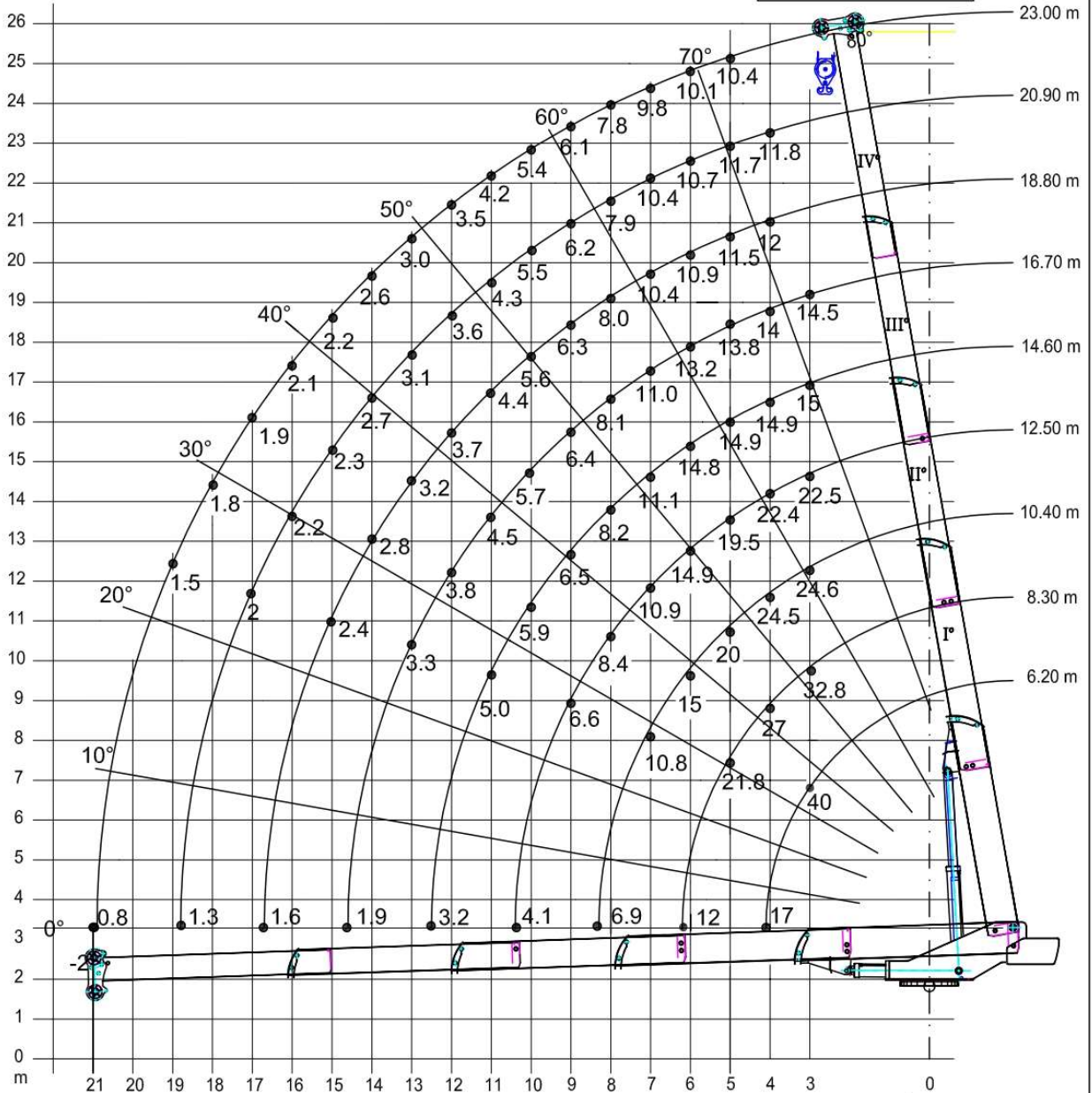

Termoli (CB) - Italy - Tel./Fax. +390875/752076 (Commerciale)

02/08/2012 | Dis. Cod. C50000001

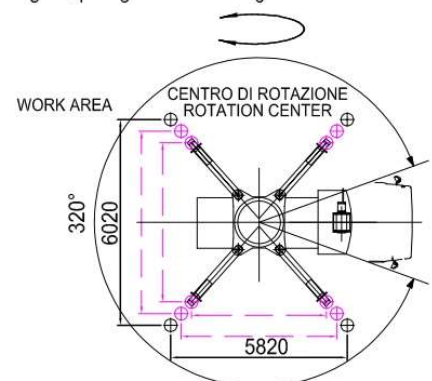

AUTOGRU' C 500
STABILIZZAZIONE COMPLETAMENTE ESTESA 6,02 m X 5,82 m – PORTATE AL 75% ESPRESSE IN t

L	6,20 m		8,30 m		10,40 m		12,50 m		14,60 m		16,70 m		18,80 m		20,90 m		23,00 m	
1	0		50		100		100		100		100		100		100		100	
2	0		0		0		50		100		100		100		100		100	
3	0		0		0		0		0		50		100		100		100	
4	0		0		0		0		0		0		0		50		100	
R, m	α°	t	α°	t	α°	t	α°	t	α°	t	α°	t	α°	t	α°	t	α°	t
3.00	43.17	40.0	58.13	32.8	65.13	24.6	69.85	22.5	72.90	15.0	75.14	14.5						
4.00	20.64	24.0	48.83	27.0	58.87	24.5	64.73	22.4	68.66	14.9	71.50	14.0	73.66	12.0	75.36	11.8		
4.10	0.00	17.0																
5.00			37.49	21.8	51.77	20.0	59.35	19.5	64.27	14.9	67.77	13.8	70.41	11.5	72.47	11.7	74.14	10.4
6.00			19.67	15.0	43.72	15.0	53.59	14.9	59.68	14.8	63.92	13.2	67.08	10.9	69.53	10.7	71.50	10.1
6.20			0.00	12.0														
7.00					33.94	10.8	47.29	10.9	54.83	11.1	59.93	11.0	63.66	10.4	66.53	10.4	68.81	9.8
8.00					19.19	8.0	40.14	8.4	49.63	8.2	55.74	8.1	60.11	8.0	63.44	7.9	66.07	7.8
8.30					0.00	6.9												
9.00							31.50	6.6	43.94	6.5	51.30	6.4	56.43	6.3	60.26	6.2	63.27	6.1
10.00							18.90	5.2	37.48	5.9	46.54	5.7	52.56	5.6	56.97	5.5	60.39	5.4
10.40							0.00	4.1										
11.00									29.71	5.0	41.32	4.5	48.46	4.4	53.54	4.3	57.41	4.2
12.00									18.70	4.7	35.41	3.8	44.05	3.7	49.93	3.6	54.32	3.5
12.50									0.00	3.2								
13.00											28.34	3.3	39.22	3.2	46.10	3.1	51.10	3.0
14.00											18.57	2.8	33.76	2.8	41.99	2.7	47.71	2.6
14.70											0.00	1.9						
15.00													27.25	2.4	37.48	2.3	44.12	2.2
16.00													18.46	2.0	32.40	2.2	40.25	2.1
16.70													0.00	1.6				
17.00															26.37	2.0	36.02	1.9
18.00															18.38	1.8	31.26	1.8
18.90															0.00	1.3		
19.00																	25.65	1.5
20.00																	18.32	1.3
20.90																	0.00	0.8
21.0																		
22.0	COD.DC50000001																	



ACCESSORI

- CONTAORE
- COLLAUDO M.C.T.C.
- BARRA DI TRAINO PESANTE CON ATTACCHI INTERCAMBIABILI
- ROTAZIONE LIBERA:
- TELECAMERA POSTERIORE CON VIDEO IN CABINA DI GUIDA
- TELECAMERA CONTROLLO ARGANO CON VIDEO IN CABINA
- ARROTOLATORE TUBO ARIA
- ARROTOLATORE CON LAMPADA PORTATILE
- CONTRAPPESO (COMPLETO DI SUPPORTO E CILINDRO DI MOVIMENTAZIONE)
- TESTA DEL BRACCIO RUOTANTE A 3 POSIZIONI (0°; -32,5° - -65°)
- VERRICELLO DI TRAINO POSTERIORE 20 TON, 50 M FUNE, DIAM. 18 MM
- CAMPANA DI TRAINO
- BILANCINO REGISTRABILE IN LARGHEZZA PORTATA 30 TON
- RADIOCOMANDO PER SGANCIO-AGGANCIO CONTRAPPESO
- DISPOSITIVO PER BLOCCO SOSPENSIONI
- FANALERIA TIPO "AMERICA" A FARI STROBOSCOPICI
- RADIOCOMANDO PER TUTTE LE FUNZIONI GRU ESCLUSO
- STABILIZZATORI (ANCHE CON DISPLAY)
- RADIOCOMANDO PER FORCA ROSPO 1.2
- KIT CASSETTE INOX (ANCHE SU MISURA)
- FARO ORIENTABILE RADIOCOMANDATO SOTTO BRACCIO
- PREDISPOSIZIONE PER ATTACCO LAMA SPARTINEVE

BILANCINO 30 TON

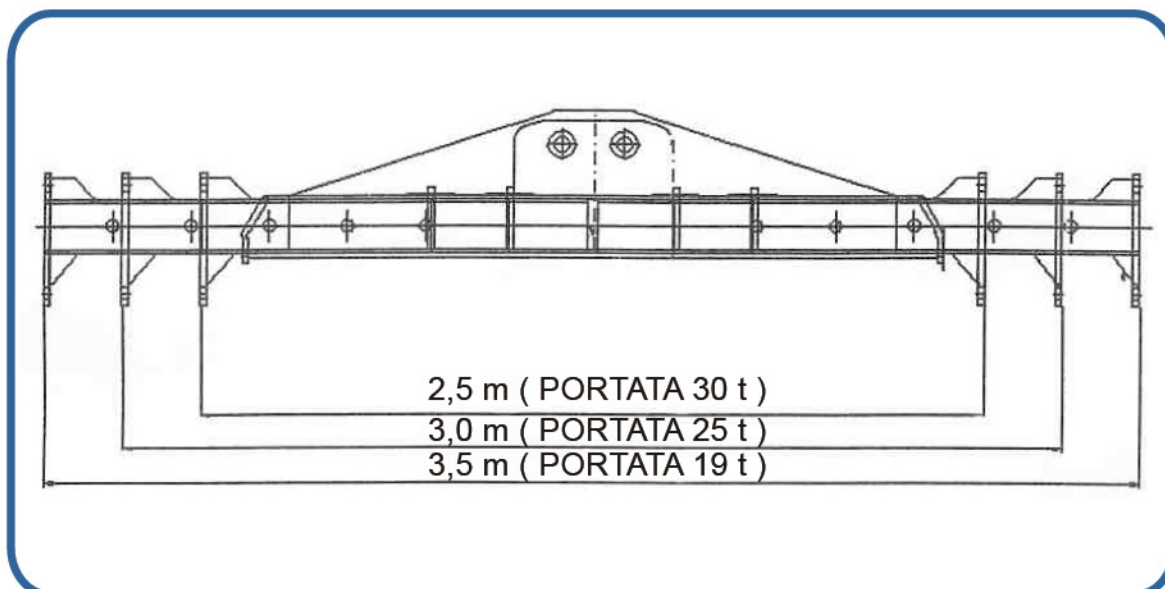

ACCESSORIES ACCESSORI

BARRA DI TRAINO



RADIOCOMANDO CON DISPLAY



BILANCINO 30TON DIETRO CABINA



PARAFANGHI IN ACCIAIO INOX



VERRICELLO ANTERIORE



FORCA ZINCATA





AGENTE ESCLUSIVO PER I PRODOTTI



 Via A. Volta, 12- 86039 Termoli (CB)

Tel./Fax: +39.0875.752076

www.tctrade.it - info@tctrade.it

www.tcmsrl.it - info@tcmsrl.it

Seguici su:

